

UN - UD CF - PD

- UN i UD: służą do ochrony gwintów i wnętrza tulei typu G podczas zalewania betonem
 - CF i PD: mocują tuleję G do szalunku podczas wlewania betonu

- Un and UD: to protect the thread and the internal of sleeve G during concrete casting

- CF and PD: to fix sleeve G on the mould during concrete casting

MOCOWANIA TULEI FILTRÓW GRAWITACYJNYCH FITTING FOR GRAVITY FILTER SLEEVES

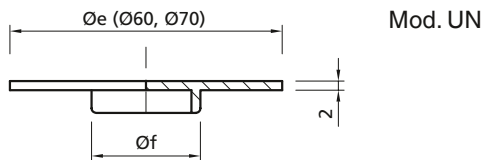

Typ Type	Øe mm	Øf mm	Gwint tulei Sleeve thread
D4.7	60, 70	25	00
	60	27	3/4" G - BSP
	60, 70	32	1.1/4" W

Materiał/Material:	PP	Dla tulei w PP For sleeves in PP
	PPFV	Dla tulei w ABS For sleeves in ABS

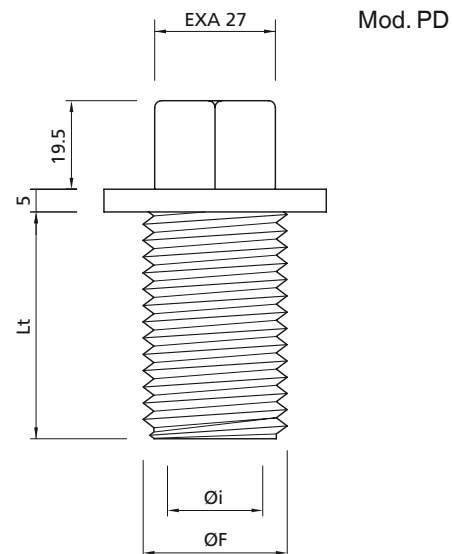

Typ Type	Øf mm	Gwint tulei Sleeve thread	Lt mm
PD	15/16" - 1" W - 1.1/4" W - M24		42, 65

Materiał/Material:	PP
--------------------	----

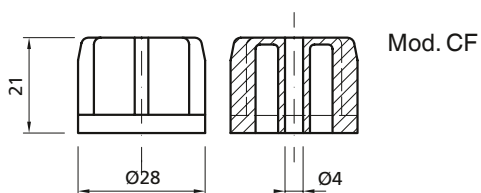
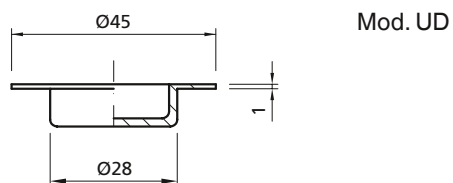

Odpowiedni dla wszystkich typów tulei G
Suitable for all types of mod.G sleeves

PRZYKŁAD ZAMÓWIENIA ORDER EXAMPLE

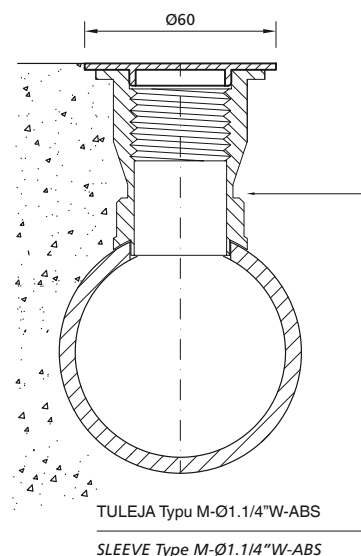
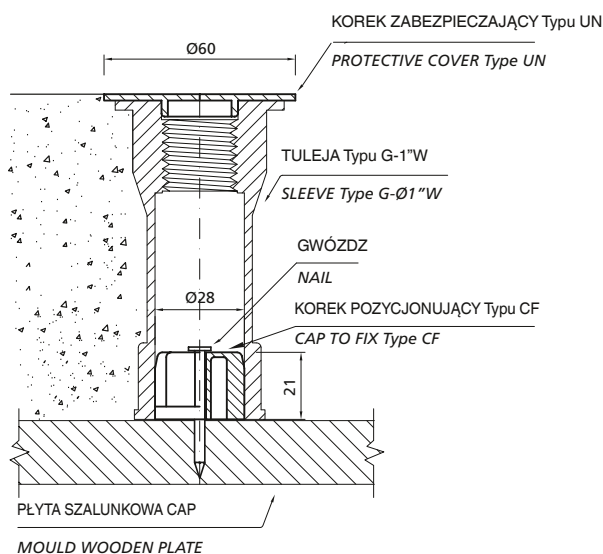

Przykład kodu zamówienia:
Example of order code:

**KOREK UN60/25-PP
CAP UN60/25-PP**

Przykład kodu zamówienia:
Example of order code:

**KOREK UN60/32-PPFV
CAP UN60/32-PPFV**